

برج خنک کننده | Cooling Tower



1. Definition:

Cooling towers are heat removal devices used to transfer process waste heat to the atmosphere. Cooling towers may either use the evaporation of water to remove process heat and cool the working fluid to near the wet-bulb air temperature or in the case of "Close Circuit Dry Cooling Towers" rely solely on air to cool the working fluid to near the dry-bulb air temperature. Common applications include cooling the circulating water used in oil refineries, chemical plants, power stations and building cooling. The towers vary in size from small roof-top units to very large hyperboloid structures that can be up to 200 meters tall and 100 meters in diameter or rectangular structures that can be over 40 meters tall and 80 meters long. Smaller towers are normally factory-built, while larger ones are constructed on site. They are often associated with nuclear power plants in popular culture, although cooling towers are constructed on many types of buildings.

2. Classification by use:

HVAC

An HVAC (Heating, Ventilating, and Air Conditioning) cooling tower is a subcategory rejecting heat from a chiller. Water-cooled chillers are normally more energy efficient than air-cooled chillers due to heat rejection to tower water at or near wet-bulb temperatures. Air-cooled chillers must reject heat at the dry-bulb temperature, and thus have lower average reverse-Carnot cycle effectiveness. Large office buildings, hospitals, and schools typically use one or more cooling towers as part of their air conditioning systems. Generally, industrial cooling towers are much larger than HVAC towers.

Industrial cooling towers

Industrial cooling towers can be used to remove heat from various sources such as machinery or heated process material. The primary use of large, industrial cooling towers is to remove the heat absorbed in the circulating cooling water systems used in power plants, petroleum refineries, petrochemical plants, natural gas processing plants, food processing plants, semi-conductor plants, and for other industrial facilities such as in condensers of distillation columns, for cooling liquid in crystallization, etc.

The world's tallest cooling tower is the 200 meter tall cooling tower of Niederaussem Power Station.

3. Heat transfer methods

With regard to the heat transfer mechanism employed, the main types are:

Wet cooling towers or simply open circuit cooling towers operate on the principle of evaporation. The working fluid and the evaporated fluid (usually H₂O) are one and the same.

Dry Cooling Towers operate by heat transfer through a surface that separates the working fluid from ambient air, such as in a tube to air heat exchanger, utilizing convective heat transfer. They do not use evaporation.

4. Air flow generation methods

With regard to drawing air through the tower, there are three types of cooling towers:

Natural draft, which utilizes buoyancy via a tall chimney. Warm, moist air naturally rises due to the density difference to the dry, cooler outside air. Warm moist air is less dense than drier air at the same pressure. This moist air buoyancy produces a current air through the tower.

Mechanical draft, which uses power driven fan motors to force or draw air through the tower.

Induced draft: A mechanical draft tower with a fan at the discharge which pulls air through tower. The fan induces hot moist air out the discharge. This produces low entering and high exiting air velocities, reducing the possibility of recirculation in which discharged air flows back into the air intake. This fan/fin arrangement is also known as draw-through.

Forced draft: A mechanical draft tower with a blower type fan at the intake. The fan forces air into the tower, creating high entering and low exiting air velocities. The low exiting velocity is much more susceptible to recirculation. With the fan on the air intake, the fan is more susceptible to complications due to freezing conditions. Another disadvantage is that a forced draft design typically requires more motor horsepower than an equivalent induced draft design. The forced draft benefit is its ability to work with high static pressure. They can be installed in more confined spaces and even in some indoor situations. This fan/fill geometry is also known as blow-through.

5. Air-to-water flow Categorization

Cross flow

Cross flow is a design in which the air flow is directed perpendicular to the water flow (see diagram below). Air flow enters one or more vertical faces of the cooling tower to meet the fill material. Water flows (perpendicular to the air) through the fill by gravity. The air continues through the fill and thus past the water flow into an open plenum area. A distribution or hot water basin consisting of a deep pan with holes or nozzles in the bottom is utilized in a cross flow tower.

Gravity distributes the water through the nozzles uniformly across the fill material.

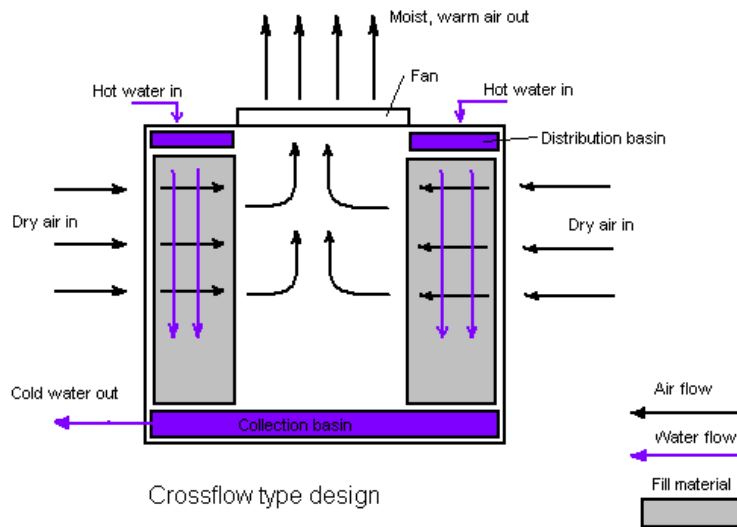

Counter flow

In a counter flow design the air flow is directly opposite of the water flow (see diagram below). Air flow first enters an open area beneath the fill media and is then drawn up vertically. The water is sprayed through pressurized nozzles and flows downward through the fill, opposite to the air flow.

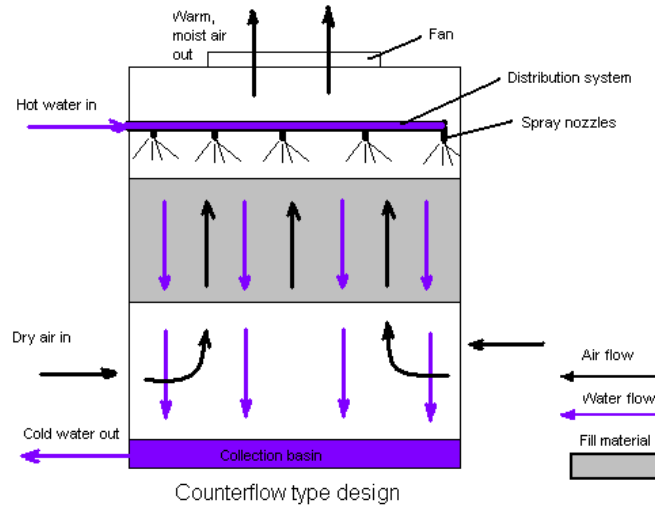

Common to both designs:

The interaction of the air and water flow allows a partial equalization and evaporation of water. The air, now saturated with water vapor, is discharged from the cooling tower. A collection or cold water basin is used to contain the water after its interaction with the air flow. Both cross flow and counter flow designs can be used in natural draft and mechanical draft cooling towers.

6. Factors which effects the capacity of cooling tower

- **Environment wet bulb temperature:** lowering wet bulb temperature
- increasing fill area
- increasing the period of air and water contact

7. Terminology

Range - The range is the temperature difference between the water inlet and water outlet. The capacity of a cooling tower can be calculated by measuring the water flow rate and the range from below equation:

$$\text{Cooling tower load (KW)} = \text{flow rate (L/S)} \times 4.19 \text{ (Kj/Kg}^{\circ}\text{K)} \times \text{Range (}^{\circ}\text{K)}$$

Approach - The approach is the difference in temperature between the cooled-water temperature and the entering-air wet bulb temperature (twb). Since the cooling towers are based on the principles of evaporative cooling, the maximum cooling tower efficiency depends on the wet bulb temperature of the air. The wet-bulb temperature is a type of temperature measurement that reflects the physical properties of a system with a mixture of a gas and a vapor, usually air and water vapor.

8. Principal of operations of "Tahviah Sarayel Nasim " conical Type Cooling

Towers

The automatic rotating sprinkler system distributes the hot water evenly over the entire fill section. Dry air is simultaneously drafted upward causing evaporation and so, the heat is removed. The cooled water falls into the basin and is pumped to the heat source for recirculation.

9. Thermal Design

The "Tahviah Sarayel Nasim" cooling towers operate on the counter flow principle which gives the best performances. The air flow through the tower fill is opposed the water flow.

The cold air meets the closed water at the bottom of the fill providing maximum evaporation and heat transfer in the fill. The PVC fill is corrugated with clear channels between flutes to prevent any blockage and giving a large surface area per unit volume. Water flows through the fill in a thin film exposed the maximum area to the cooling air flow. The flutes of the fill area at an angle and each layer of fill section are reversed, turning the film or water and air over for maximum cooling.

10. Better Air Flow

The rotating water sprinkler head distributes the hot water which forming a fine spray, and hence does not need the conventional type of moisture eliminator. This is because the water header has large number of holes giving a 'steam' type flow direct into the fill. Tower with fixed nozzles cannot obtain the coverage, which is needed for optimum cooling. We should not overlook that in rectangular type towers, eliminators provide a pressure drop which evens out the flow particularity into the corner.

The "Tahviah Sarayel Nasim" cooling tower being round, plus its conical fan inlet can better provide an even air flow through the fill, with a lower pressure drop, and without the additional pressure drop caused by the eliminator needed on other towers. Fan KW depends on the mass of air delivered, the pressure generated and the blade efficiency, from the available data on other manufacturers' tower. "Tahviah Sarayel Nasim" air volumes are similar to competitor's size. The influence factors for lower power are 'pressure' and 'efficiency'. Tower has large air inlet area, with low air velocity; low pressure drop tower is of the induced draft type. The fan is in the ideal position, to discharge the air at a high velocity upwards and allow natural convection to prevent recirculation, as can happen with the forced draft tower arrangement, where air leaves the eliminator at low velocity.

11. Pumping head

As seen already, the water distribution by a rotating header is a significant part of the "Tahviah Sarayel Nasim" tower design. The large diameter holes in the rotating header give a gentle stream of water at negligible pressure lose. Also, there is no risk of 'clogging', as can easily happen with spray nozzles in other types of towers.

The "Tahviah Sarayel Nasim" cooling towers pumping head, is the static height of the spray or header pipe above the water level in basin, plus the pressure loss the rotating header, sprays of balancing valves, according to the type of tower being considered.

It should be noted that pumping heads quoted for "Tahviah Sarayel Nasim" towers include both of these as well as piping inside the pressure loss of sprays is usually quoted. To this must be added the static lift to the spray header from the basic required for a "Tahviah Sarayel Nasim" cooling tower 50% less than for some other cooling towers.

12. Lift factor

Although we generally refer to the towers as being constructed of fiberglass, we should actually refer to them as being FRP (Fiberglass Reinforced Plastic) should not be confused with the translucent fiberglass roofing panels, and in particular with the cheaper grades which have given poor results even only in a few years. Without an adequate protective layer, the sun's ultra violet rays draw the fibers upwards so that 'hairs' appear to be growing on the panels as with fiberglass hulls, the "Tahviah Sarayel Nasim" towers do not need painting. However, if a client wishes to have color scheme changed, painting is possible.

Compared with timber towers which will ultimately rot, or steel towers which will rust despite increased maintenance, the fiberglass tower has tremendous financial advantages for the wise investor. Unfortunately, many buyers appear to be only concerned to maintenance, running costs or rate of deterioration.

13. Smaller Fan Motors

Smaller electric motor in "Tahviah Sarayel Nasim" cooling towers, causes lower consumption power and save money.

14. Advantages of "Tahviah Sarayel Nasim" Cooling Towers:

- *Strong FRP layers used isophetalic resin, no vibration and increase the life of cooling tower.*
- *Neopentyl glycol (NPG) anti-UV causes long lasting color, decorative and long life.*
- *FRP sump*
- *Fill are made of Virgin antibacterial PVC films.*
- *Fans are dynamically balanced for smooth operation, longer bearing life including that of the supporting structure.*
- *The fan drive motor is in IP-55, "F" class.*
- *5 years warranty insures you a right purchase.*

15. Components

The various components of FRP conical type cooling tower are as below:

Casing

The bolt together FRP casing is completely non-corrosive. The casing enclosed the PVC fills services to isolate the air stream, which passes over the fills. The casing is conical shaped to reduce frictional resistance of air and aids flow pattern. It is designed to withstand wind loads up to 75km/hr., and vibrations emanating from the motor and other equipment. FRP casing has a high impact resistance when laminated with Isophetalic Resin and even if damaged is easily repaired at site. The neopentyl glycol gel coat is U.V. inhibited to provide a long lasting finished appearance and service life and imported wax release agents helps retain colors for long periods even if exposed to direct sunlight. The casing is in sections of easy to handle sizes and is assembled at site using bolting joints. The conical shape of casing is ideal with regard to cooling efficiency and space economy.

Basin

The basin serves the purposes of collecting the water descending from the fills and channeling it to the suction point. Further the basin also acts as a reservoir of water.

The basin is also made of FRP and has similar characteristic the same as casing.

Sump

The sump is located below and in the center of the basin and has all connections for inlet/outlet, drain, filling and overflow. The unit is at the lowest point and is always flooded and thus ensuring no capitations on the pump suction. The suction tank is fully molded in FRP to prevent corrosion and subsequent leakages. A drain is provided to the tank which makes it quite simple to remove the accumulated dirt and to drain out the water, simplifies the cleaning and maintenance of the tower.

Tower Structure

The structure of the tower supports the casing, basin and motor mounting loads to the foundations. These are of MS and are hot dipped galvanized so as to resist corrosion.

Fills

The fills section is designed to bring about intimate contact of water and air so as to facilitate heat and mass transfer at the same time aiding in proper and even distribution of air and water over the cross section, while maintaining minimum pressure drop. The fills are of honeycomb section and are vacuum formed from anti-bacterial Virgin PVC for excellent resistance to corrosion and give maximum area for intake.

Sprinkler

The gravity die cast aluminum alloy / S.S sprinkler is used to distribute the water evenly over the cross section of the tower. An aluminum alloy / S.S rotary head with radial PVC / PP pipes having drilled holes serves this purpose. The rotation of assembly is accomplished due to reaction of water jet being sprayed from PVC / PP pipes. The sprinkler head is mounted on top of the central water supply. To ensure free rotation even at low flows the sprinkler has 2 sealed pre lubricated ball bearing mounted on the central shaft. This sprinkler system is preferred over the fixed nozzle system for various reasons.

Fan / Fan Blades

The light weight fan has good corrosion-resistant quality is an axial flow, multi blade version with adjustable blade pitch. The fan is designed to deliver large volumes of air at low power consumption and low noise generation. The fans are dynamically balanced for smooth operation, longer bearing life including that of the supporting structure. FRP fan blades may also be provided on demand and these have in addition to excellent corrosion-resistance, good noise reduction properties.

Fan Drive Motor

The fan drive motor is in IP-55 'F' class design. The fan is directly driven by the special extended shaft motor made from steel mounted facing downward on a mounting frame on the top of the Cooling Tower.

Louvers

FRP louvers are installed at the air inlet (space between the Tower casing and water Basin) to prevent water splash and contaminants like leaves, bird etc. entering the Cooling Tower.

Grills

Since Cooling Tower are generally installed on windswept rooftop or higher altitude, galvanized MS grill are installed at the air outlet to prevent contaminants like leaves, bird etc. entering the cooling tower.

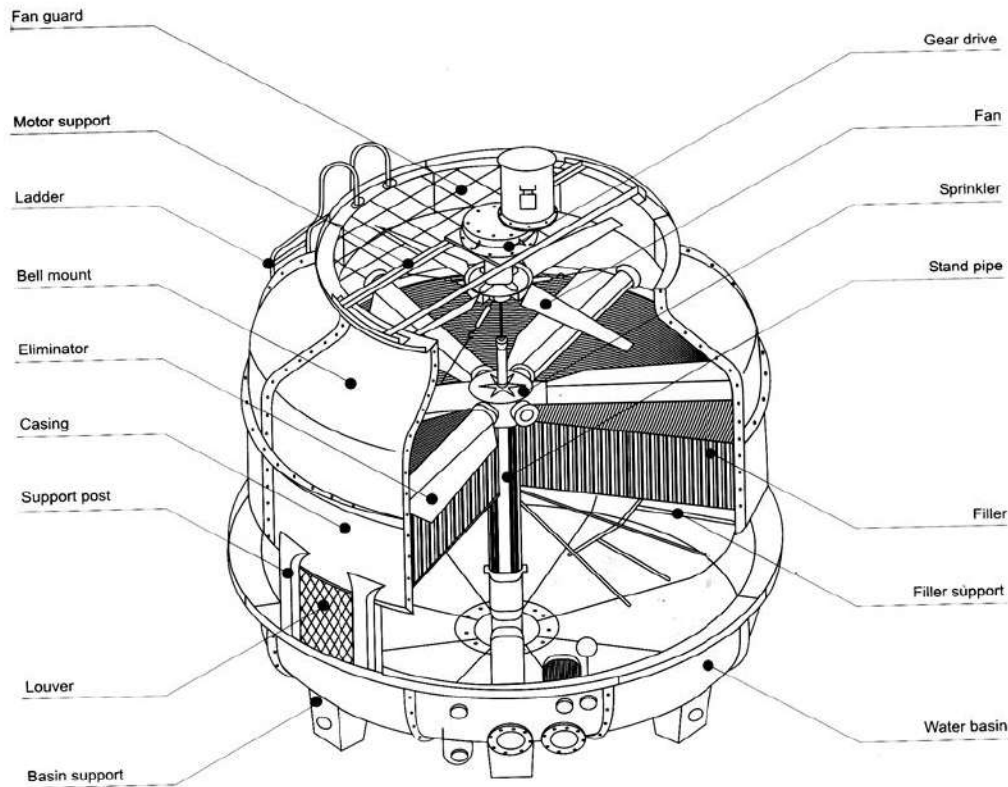

Drift Eliminators

Units with rotary sprinklers are designed to minimum carry over by judicious choice of air flow velocities. The air distribution is aided by using a centrally located rotating eliminator section to avoid high velocity area. Further the pipes are covered by aero foil section eliminators which prevent small droplets escaping and facilitate uniformly distributing the sprinkler water. For the towers using stationary sprinkler nozzles a full width eliminator covering the full cross section is used. The shape of the eliminator is chosen to minimize pressure loss of air and to trap the maximum amount of droplets.

16. Water loss

Water losses are very important especially in dry zones. Water losses in cooling towers are based on four items;

Evaporation

Drift

Bleed off

Pipe line and valves leakages

Evaporation

The evaporation rate can be estimated from the below equation:

$$E=0.0008(T_i-T_o) \times F$$

E=evaporation rate (gpm)

T_i & T_o = inlet and outlet temperatures $^{\circ}F$

F= water flow rate (gpm)

Drift

Water droplets that are carried out of the cooling tower with the exhaust air. Drift droplets have the same concentration of impurities as the water entering the tower. The drift rate is typically reduced by employing baffle-like devices, called drift eliminators, through which the air must travel after leaving the fill and spray zones of the tower. Drift can also be reduced by using warmer entering cooling tower temperatures.

The drift loss in “Tahviah Sarayel Nasim” cooling towers is less than 0/002% of water flow rate, so the maximum drift loss can be calculated from below equation:

$$D=0.002 \times F$$

Bleed Off

The portion of the circulating water flow that is removed in order to maintain the amount of dissolved solids and other impurities at an acceptable level. It may be noted that higher TDS (total dissolved solids) concentration in solution results in greater potential cooling tower efficiency. However the higher the TDS concentration, the greater the risk of scale, biological growth and corrosion.

“Tahviah Sarayel Nasim” suggested the flowing rates for bleed off as given in below table:

Bleed off can be calculated by multiplying water flow rate into the coefficient given above.

Bleed off pipe should be installed on return pipe from condenser to cooling tower and near the tower so that when the pump is running bleed off takes place.

Pipe line and valves leakage

Water losses from pipe lines and valves are depends on the quality and connections.

17. Preparation for Installation

- 1- Declare all components, open all packages, and confirm nothing is damaged.
- 2- Check all components received as per packing slip (including fiberglass mat and resin)
- 3- Collect all tools and tackles as needed:
 - Spanners / - drill & drill bit / - pipe wrench / - screw driver / - plier / - hammer
 - files / - spirit level , pipe level / - slitting knife / - brush / - roller

Cooling Range °F	Percent Bleed off
5	0.1
6.5	0.16
7.5	0.21
10	0.33
15	0.55
20	0.75

- 4- Check concrete foundation, is as per drawing.
- 5- Check level of foundation legs and correct if required.
- 6- Install suction tank on central foundation, with correct orientation as decided by client.
- 7- Install cylindrical legs on circumference foundation.
- 8- Level top side with pipe level.

- 9- Install basin supporting ring and bolt together, with supporting legs.
- 10- Bolt basin FRP section and place on top of Basin Ring.
- 11- Install Grill which supports upper Ring support legs on top of Basin on edges.
- 12- Install upper ring and bolt to legs.
- 13- Install casing sections piece by piece and bolt together to next piece to form complete cylindrical shape.
- 14- Install motor supporting ring / bracket.
- 15- Install ladder.
- 16- Install motor and fan set.
- 17- Connect inlet stand pipe.
- 18- Connect sprinkler mounting pipe.
- 19- Connect P.V.C pipes to sprinkler.
- 20- Screw in pipes and end caps and lock with locknut (for large towers turn buckles are to be used for maintaining PVC pipes horizontally.)
- 21- Install clamp on central pipe.
- 22- Install cross containers of cooling surfaces.
- 23- Flatten plastic cooling support on the containers.
- 24- Install cooling surfaces on grid vertically, stating with diametrically placed packs fill up the rest of grid.
- 25- Install next fill pack layer at right angles to 1st layer
- 26- Seal Basin flanges and suction tank with fiberglass mat and resin, and allow drying before using.
- 27- Install motor / fan protection grid.
- 28- Install grill and louvers.
- 29- Brush coat bolt heads with resin for additional protection.
- 30- Provide bottom support for ladder.
- 31- Sprinkler assembly
- 31-1- sprinkler pipes

The sprinkler pipes must be clean to prevent any blockage in their holes. When cleaning the sprinkler pipes, loosen the lock nut to unscrew and remove the sprinkler pipes. On reassembling, be sure the alignment screws (round head) are positioned at the top center

30-2 sprinkler hand

Scale or sludge attached to the narrow space impedes revolution. If the sprinkler rotation slows down or even stops despite normal water flow the sprinkler pipes or, at the beginning of the season, if the head does not rotate even though the water is flowing at the same rate as last season, dismantle the rotary head for cleaning and checking.

When reassembling, do not wet the bearing portion with water and apply ample anticorrosion lubricant (water proof, lithium soap- radical grease) on bearings and oil seals position. Also pay particular attention when passing the oil seal over the center poll to not to damage the lips of the oil seal. Since oil seal is effective for a limited period, it is desirable to dismantle and replace it every two or three years.

18. Normal conditions

Water quality and environmental conditions on the vast majority of HVAC cooling tower applications permit acceptable service life from standard cooling tower construction using the materials previously described. Significant deviation from these normal conditions often demands alternate materials choices.

For most proposes the following criteria define "normal" conditions:

Standard tower design assumes a maximum of 120⁰F hot water to the tower, including system upset conditions. Temperatures over 120⁰ F, even for short duration, may impose damaging effects on PVC fill, many thermoplastic components, galvanizing and play woods. Those rare applications demanding hot water in excess of 120⁰ F usually benefit from careful review with the tower manufacturer to assure that appropriate materials changes from standard configuration are included in the initial purchase specification.

"Normal" circulating water chemistry falls within the following limits (note the distinction between circulating water and make-up water):

--ph. between 6.5 and 8.0, although ph. down to 5.0 is acceptable if no galvanized steel is present. Low ph. attacks galvanized steel, concrete and cement products, fiberglass and aluminum. High ph. wood, fiberglass and aluminum.

--chlorides (express as NaCl) below 750 ppm.

--Calcium (as CaCO₃) below 1200 ppm-except in arid climates where the critical level for scale formation may be much lower.

--sulfates below 5000 ppm if calcium exceeds 1200 ppm sulfates should be limited to 800 ppm, (less in arid climates) to prevent scale formation.

--sulfides below 1ppm

--Silica (as SiO₂) below 150 ppm

--iron below 3ppm

Manganese below 0.1ppm

-- saturation index between -0.5 and +0.5 negative LSI indicates corrosion likely; positive indicates CaCo₃ scaling likely.

--suspended solids below 150ppm if slides are abrasive avoid film-type fills, is solids are fibrous, greasy, fatty or tarry wood, PVC, Polypropylene or ABS fills can be used, but PVC usually is the material of choice.

--oil and grease below 10ppm or loss of thermal performance will occur.

--no organic solvents

--no organic nutrient, which could promote growth of algae or sludge.

--chlorine (from water treatment below 1ppm free residual for intermittent treatment below 0.4ppm free residual for continuous chlorination

These conditions define normal circulating water, including the chemical concentrating effects caused by recalculating the water to some predetermined number of concentration.

19. Water quality control

Cooling towers not only are very effective but also sensitive air washers. Atmospheric dust able to pass through the air inlet will enter the circulating water or air pollution, such cases as corrosion, scale and algae growth which impeded the performance of air conditioning equipment are surprisingly increasing. To prevent such trouble, it is not enough to depend entirely upon chemical or equipment. Check the water quality and also on environment factors as well.

1. *Make quality analysis of circulating water and supplementing water and take appropriate action to control the quality.*
2. *If when the trouble is anticipated owing to the condensed circulation water, we recommended the use of chemical, periodic below sown to keep the operation within the regulate water quality.*
3. *For nitrate and sediment, clean with chemicals.*
4. *Use strainer or filter depending on the water quality.*

WARNING

Water treatment must be supplied and / or applied by a professional in the field in order to avoid fill damage. It is the user's / owner's responsibility to treat water in order to stop biological contaminants and avoid among other bacterium, the Legionella bacteria, which is known to cause legionnaire disease.

20. Post assembly Checks/ Pre-commissioning Checks

1. *Check level of sump, and fan ensure they are parallel to ground.*
2. *Check center pipe is vertical and sprinkler arms are all leveled, at right angles to center pipe.*
3. *Ensure no dirt/other foreign particles are present in sump, suction tank etc. sweep clean/wash clean.*
4. *Rotate sprinkler with hand and ensure it is free.*
5. *Ensure fill top is even.*
6. *Ensure sprinkler arms are at a constant level above the fills and that the arms do not rub against/ uneven fills, casing etc.*
7. *Ensure fan and motor assembly is free.*
8. *Check all bolts are tight and no loose part noticed.*
9. *Fill water in sump and check and eliminate water leaks.*
10. *Connect correct power (i.e. 380V, 50Hz 3PH. AC) supply to fan and check.*
 - a. *Direction of rotation of fan is correct and air is being sucked through screen above sump and discharged vertically upwards.*
 - b. *Vibrations are negligible.*
 - c. *Fan cable connections are made with lugs & terminal cover gasket is tight.*
11. *Establish water flow and check sprinkler rotates and check any unregulated bypass from sprinkler pipes.*

Check after commissioning

1. *Check motor speed to be as specified in technical data for particular model.*
2. *Check air flow rate is as per specification.*
3. *Check water flow rate is as per specification.*
4. *Check power / current drawn by fan motor are within limits and as specified.*
5. *Check for abnormal noise / vibration during operation.*
6. *Check sprinkler rotates freely at 5 to 8 rpm or adjust holes to angle so as to achieve correct rpm.*
7. *Ensure water is being distributed evenly over the FRP eliminator plates and there is no carry over from below the eliminator plate water must fall down below evenly and not pass out.*
8. *Eliminator plate adjustment to be checked to ensure equal distance between fill top and plat bottom.*

9. *Measure temperature at following locations:*
 - i. *Water inlet*
 - ii. *Water outlet / sump*
 - iii. *Make up water inlet*
 - iv. *Wet bulb / dry bulb temperature at outlet of tower above fan*
10. *Adjust drain valve to give adequate blow down.*
11. *Set float to ensure proper operation and to avoid over flow when plant stops.*

Maintenance Schedule

Every Day

Check if–

1. *Vibrations are normal / noise normal.*
2. *Proper Water distribution.*
3. *Measuring every three phases of fan.*
4. *Normal Inlet / outlet temperature of water*

Every week:

1. *Clean inlet grill to remove entrained matter.*
2. *Clean inlet water filter.*
3. *Clean sprinklers / nozzles if choked.*
4. *Check growth of Algae etc. and remove from sump.*
5. *Check belts stiffness.*

Every month:

1. *Drain tank, flush out and remove any sediment.*
2. *Check fills if clogged due to Allege, sediment / salt, etc.*
3. *Check structural / FRP casing and Basin damages.*
4. *Clean outside of the tower with detergents like soap and water.*
5. *Check and tighten all bolts.*
6. *Grease bolts to facilitate easy opening in future.*

Every two months:

1. *Grease all bearings of motor.*
 2. *Grease all bearings of sprinklers.*
 3. *Check run out on fan motor Shafer.*
 4. *Clean blades from foreign materials.*
 5. *Check conditioner plates if damaged and replace it.*
- Replace bearings of sprinkler assembly after 2 years and grease it.*

<i>Table1 TROUBLESHOOTING</i>		
<i>Trouble</i>	<i>Cause</i>	<i>Remedy</i>
Lowering of cooling capacity 1- Motor	Electric blackout 1	Electric blackout 1
	Fuse burned due to damage contacts	Fuse burned due to damage contacts
	Insufficient switch capacity Bad switch contact	Insufficient switch capacity Bad switch contact
2- Sudden lowering of motor speed (rotation per minute)	Electric blackout 1	Electric blackout 1
	Fuse burned due to damage contacts	Fuse burned due to damage contacts
	Insufficient switch capacity	Insufficient switch capacity
3- Con not rev up motor speed (rotation per minute)	Defective starter / starter connection	a. Correct connection according to name plate b. Check supply voltage across 3 phases c. Check current in all 3 phases
	Fuse burned due to damage contacts	Fuse burned due to damage contacts
	Insufficient switch capacity	Insufficient switch capacity
4- Fan stoppage	Jammed Bearing	Replace bearing
	Too heavy load	Lighten load proper level
Temperature rise 1- Motor getting over heated	a. lowering of voltage supply b. unbalanced voltage supply	a. consult power company b. consult power company
	High surrounding temp	Consult Sarayel Nasim
	Contact between rotary and fixed section	Change bearing or supplement grease
Oil leaking , others 1- In case of gear speed reducer oil leakage	Too much oil	Lower the oil face to proper level
	Loose bolt	Tighten properly
	Water flow above specified	Regulate to correct flow rate
Raise in discharging water temperature	Water flow below specified	Adjust blade angle check and clean jail
	Load higher than design	Adjust load to correct level
	Fill checked or coated	Clean / replace fills. Use proper water (make up) quality
	Fresh air intake not sufficient or area sufficient or area around tower not as specified	Improve ventilation and ensure exhaust air does not get recycled
	WBT high	Check design condition and ensure no recycling of exhaust air
	Water bypassing fills	Check sprinkler and distribution system
	Sprinkler jammed / water not being sprinkler and distributed	Repair sprinkler and distribution system
Water flow reduction	Filter choked	Clean water filter
	Sprinkler pipes choked	Clean pipes and holes
	Level of water low in pump	Adjust float / inlet flow ensure proper make-up
Air flow reduction	Pump small	Replace for correct flow volume
	Fan speed low	Check bearings / motor
	Fan blade angle in correct	Correct blade angle required setting
Water splash	Inlet grill choked	Clean air path
	Sprinkler is rapid	Adjust it
	Filter choked	Clean or replace it
Noise and vibration	Eliminator is defective	Replace or repair it
	Fan mounting loose	Tighten mounting bolt and correct / replace if needed
	Fan block loose	Tighten blade in hub
	Fan unbalanced	Rebalance and adjust
	Motor bearing faulty	Check and grease or replace bearing on motor
	Hub mounting on motor shaft loose	Tighten and use end plate and shims if needed
Many parts rubbing against tower components	Give proper clearances and adjust / align components	

After the inspection and troubleshooting process, contact the after sale services of Sarayel nasim co. otherwise, the problem shall be fixed by authorized personel.

Conical type FRP cooling towers technical specifications

Table 2

Model	Nominal water flow (GPM)	Motor power (Kw)	Fan		Pump Head (m)	Dimensions (cm)		Weight (Kg)			
			Dia (cm)	Nominal Air flow (CFM)		Standard and Low Noise type		Standard type		Low Noise type	
						Height	Dia.	Dry	Full	Dry	Full
5-085	28	0.18	50	2800	1.3	135	85	50	118	52	120
10-093	35	0.18	60	3180	1.3	163	93	56	138	58	142
15-117	53	0.37	80	6360	1.6	168	117	83	218	85	220
20-138	71	0.37	80	7000	1.6	178	138	110	264	113	268
25-138	88	0.37	80	7770	1.8	202	138	115	329	118	332
30-163	105	0.75	90	8480	2	189	163	160	363	164	367
40-178	141	0.75	90	9410	2	200	178	171	410	175	414
50-187	176	1.1	90	11300	2.2	234	187	215	515	219	519
60-199	212	1.5	120	14500	2.5	237	199	399	708	405	714
70-215	247	1.5	120	16000	2.5	215	215	420	777	426	783
80-215	282	1.5	120	17100	2.5	248	215	431	792	437	798
90-259	318	1.5	120	21800	3.1	235	259	459	854	471	864
100-259	352	1.5	120	24100	3.1	257	259	519	943	529	953
125-295	442	2.2	150	27500	3.5	238	295	629	1053	644	1068
150-295	528	4	150	29700	3.5	262	295	789	1468	804	1483
175-333	618	4	180	32900	3.8	262	333	874	1553	890	1569
200-371	705	4	180	47100	4.4	292	371	1342	3043	1360	3060
225-371	795	5.5	180	57100	4.4	315	371	1462	3162	1480	3180
250-439	880	5.5	240	66500	4.7	328	439	1657	3357	1678	3379
300-439	1050	5.5	240	76900	4.7	366	439	1766	3473	1788	3494
350-485	1230	7.5	240	83500	5	345	485	1861	3861	1885	3885
400-485	1410	11	240	90700	5	368	485	2305	4305	2329	4329
450-551	1580	11	300	106500	5.3	404	551	2535	5818	2565	5848
500-551	1770	11	300	119500	5.3	427	551	2590	7155	2619	7185
600-653	2120	11	330	139500	5.6	460	653	3493	10588	3524	10619
700-653	2460	15	330	171000	5.6	483	653	3652	10747	3684	10779
800-759	2830	18.5	360	197100	6.2	500	759	5229	12808	5264	12843
1000-759	3520	22	360	217700	6.2	523	759	5449	13247	5483	13282
1250-879	4400	22	420	270700	6.5	556	879	6476	15458	6516	15497

Conical type FRP cooling towers technical specifications

Table 3

<i>Model</i>	<i>Inlet</i>	<i>Outlet</i>	<i>Over Flow</i>	<i>Drain</i>	<i>Quick</i>	<i>Float Valve</i>
5-085	1.5	1.5	1	1	1/2	-
10-093	1.5	1.5	1	1	1/2	-
15-117	2	2	1	1	1/2	-
20-138	2	2	1	1	1/2	-
25-138	2	2	1	1	1/2	-
30-163	3	3	1	1	1/2	-
40-178	3	3	1	1	1/2	-
50-187	3	3	1	1	1/2	-
60-199	4	4	1.5	1.5	3/4	-
70-215	4	4	1.5	1.5	3/4	-
80-215	4	4	1.5	1.5	3/4	-
90-259	4	4	1.5	1.5	3/4	-
100-259	4	4	1.5	1.5	3/4	-
125-295	4	4	1.5	1.5	3/4	3/4
150-295	4	4	1.5	1.5	3/4	3/4
175-333	6	6	1.5	1.5	3/4	3/4
200-371	6	6	3	1.5	1	1
225-371	6	6	3	1.5	1	1
250-439	6	6	3	1.5	1	1
300-439	8	8	3	1.5	1	1
350-485	8	8	3	1.5	1	1
400-485	8	8	3	1.5	1	1
450-551	10	10	4	3	2	2
500-551	10	10	4	3	2	2
600-653	10	10	4	3	2	2
700-653	10	10	4	3	2	2
800-759	12	12	4	3	3	3
1000-759	12	12	4	3	3	3
1250-879	12	12	4	3	3	3

Galvanized Cooling Tower Dimensions

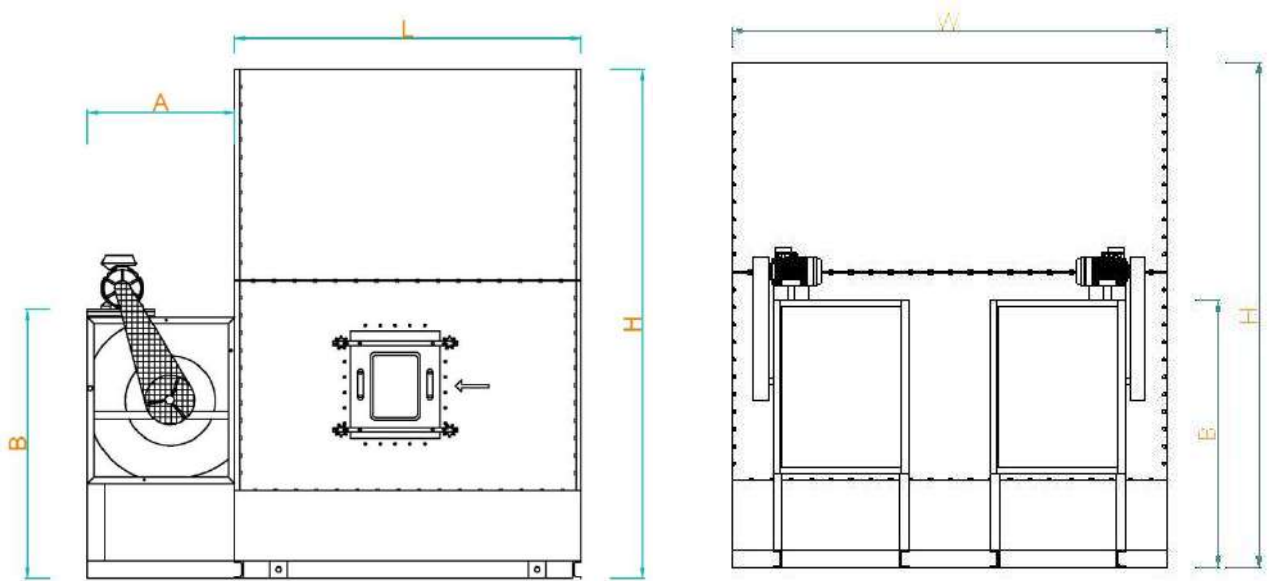
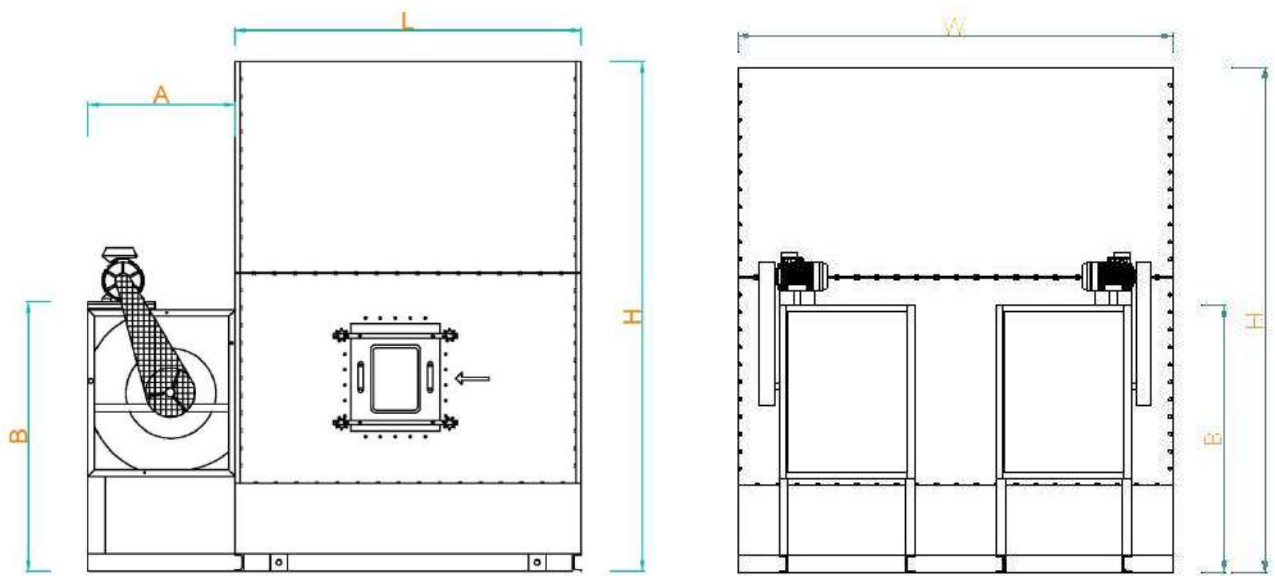

Table 4

Model	Dimensions (mm)					Outlet Water		Inlet Water		Weight (Kg)
	L	W	H	A	B	No.	Size (Inch)	No.	Size (Inch)	
10	560	945	2150	533	460	1	1 ½	1	1 ½	285
15	740	945	2150	620	540	1	1 ½	1	1 ½	345
20	945	945	2200	750	655	1	2	1	2	410
25	945	1300	2200	750	655	1	2	1	2	500
30	945	1450	2250	1060	847	1	3	1	3	620
35	945	1450	2250	1060	847	1	3	1	3	695
40	1000	1940	2250	1060	847	1	3	1	3	755
50	1210	1940	2250	1060	847	1	3	1	3	880
60	1460	1940	2900	1060	847	1	4	1	4	1080
80	1940	1800	2900	1060	847	1	4	2	3	1500
90	1940	1940	2900	1060	847	1	4	2	3	1590
110	1940	2560	2900	1060	847	1	5	3	3	1790
120	1940	2890	3000	1060	847	1	5	3	3	2250
140	1940	3400	3000	1060	847	1	5	4	3	2500
160	1940	3860	3000	1060	847	2	4	4	3	3150

Galvanized Cooling Tower Dimensions



Cont. Table 4

Model	Dimensions (mm)					Outlet Water		Inlet Water		Weight (Kg)
	L	W	H	A	B	No.	Size (Inch)	No.	Size (Inch)	
180	1940	4400	3000	1060	847	2	4	5	3	3300
220	1940	5170	3000	1060	847	3	4	5	3	3850
260	1940	5670	3000	1060	847	3	4	6	3	4500
300	1940	6600	3000	1060	847	3	5	7	3	5200
340	1940	8000	3000	1060	847	3	5	8	3	5900
400	3780	5260	3100	1060	847	3	5	10	3	6900
450	3780	5730	3100	1060	847	3	5	12	3	8500
500	3780	6200	3100	1060	847	3	5	12	3	8800
590	3780	7120	3100	1060	847	3	5	14	3	9500
660	3780	8060	3100	1060	847	3	5	16	3	1140
750	3780	9000	3100	1060	847	3	5	18	3	12700
820	3780	9950	3200	1060	847	3	5	20	3	14400
900	3780	10840	3200	1060	847	3	5	22	3	15500
980	3780	11840	3200	1060	847	3	5	24	3	16700
1060	3780	12790	3200	1060	847	3	5	26	3	18150
1150	3780	13740	3200	1060	847	3	5	28	3	19400

Table 5

Model	GPM	Air Flow CFM	Fan		Motor power		Pump Head (meter)
			No.	Size (Inch)	No.	Size (Hp)	
10	30	2850	1	12	1	3/4	23
15	45	4200	1	16	1	1 ½	23
20	60	5700	1	18	1	2	23
25	75	7000	1	18	1	3	24
30	90	8500	1	22	1	3	24
35	105	9950	1	22	1	4	24
40	120	11400	1	22	1	5.5	24
50	150	14000	1	22	1	7.5	24
60	180	17000	1	22	1	7.5	24
80	225	24000	2	22	2	5.5	24
90	270	25000	2	22	2	5.5	24
110	330	29000	2	22	2	5.5	24
120	360	33000	3	22	3	5.5	24
140	420	40000	3	22	3	5.5	25
160	480	46000	4	22	4	5.5	25
180	540	49500	4	22	4	5.5	25
220	660	57000	5	22	5	5.5	25
260	780	68000	6	22	6	5.5	25
300	900	79500	7	22	7	5.5	25
340	1020	90000	8	22	8	5.5	25
400	1200	106000	10	22	10	5.5	25
450	1350	126000	12	22	12	5.5	25
500	1500	140000	12	22	12	5.5	25
590	1770	165000	14	22	14	5.5	25
660	1980	184000	16	22	16	5.5	25
750	2250	210000	18	22	18	5.5	25
820	2460	229000	20	22	20	5.5	25
900	2700	252000	22	22	22	5.5	25
980	2940	274000	24	22	24	5.5	25
1060	3180	296000	26	22	26	5.5	25
1150	3450	322000	28	22	28	5.5	25

FRP Cubic Cooling Tower

Principals of FRP Cubic Cooling Tower operation

"Tahviah Sarayel Nasim" Fiberglass Cooling towers are inspired from the well-known "Sulzer" cooling tower design, and are designed and manufactured considering local Iranian facilities and requirements. The most important change in this design is considering service hatches which unfortunately are not considered in original design.

Casing

Different parts of fiberglass body would be connected to each other by galvanized bolts and nuts and make the strong integrated body of the tower.

The tower body can bear the wind pressure up to 21 m/s. and it thwart the vibrations caused by electro motor and fan.

Basin

The integrated rigid and reinforced basin is designed so that the amount of water reserves in basin should be as when the pump starts , air does not trap and when the pump is turn off water does not overflow the basin.

Fan Deck and Fan Stack

The integrated rigid fan deck and fan stack, reinforced by fiberglass is designed to assist the air flow path.

Fills

Fiberglass cubic cooling towers suit two types of fills, film type and splash type. Cooling tower fills are designed to have the maximum contact of air with the water and cause the minimum pressure downfall.

Fan

The light weight fan has good corrosion-resistant quality is an axial flow, multi blade version with adjustable blade pitch. The fan is designed to deliver large volumes of air at low power consumption and low noise generation. The fans are dynamically balanced for smooth operation, longer bearing life including that of the supporting structure. FRP fan blades may also be provided on demand and these have in addition to excellent corrosion-resistance, good noise reduction properties.

Electromotor

Single speed electromotor, Standard TEFC with IP55, "F" class are used in "Tahviah Sarayel Nasim" cooling towers.

Water Distribution system

Large orifice polymeric nozzles (Non-clogging) are one of the significant benefits of cubic towers comparing the sprinklers of FRP conical type cooling towers.

Drift Eliminator

PVC drift eliminator with three changes in air path gives us less than 0.002% drift loss.

Considering the conditions of the area (height from the sea level) there is the option of changing the capacity of electromotor.

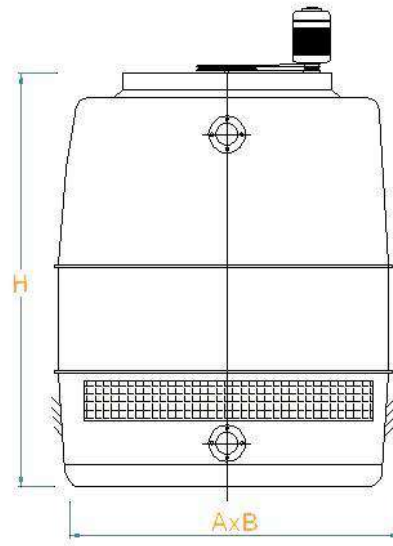

Table 6

Model	GPM	Dimensions (mm)			Motor power Kw	Inlet (inch)	Outlet (inch)	Weight Kg	
		Length	Width	Height				Dry	Full
49.1	20	700	700	1300	0.37	1	1	45	105
49.2	30	700	700	1450	0.37	1	1	56	128
49.3	40	700	700	1600	0.55	1	1	65	140
72.1	50	850	850	1740	0.55	2	2	115	240
72.2	60	850	850	1740	0.55	2	2	121	250
72.3	80	850	850	2040	0.75	2	2	127	260
169.1	90	1300	1300	2320	0.75	3	3	270	587
169.2	135	1300	1300	2320	1.1	3	3	290	660
169.3	150	1300	1300	2320	1.5	3	3	310	695
272.1	186	1650	1650	2360	1.5	4	4	390	1220
272.2	218	1650	1650	2360	2.2	4	4	410	1330
272.3	235	1650	1650	2660	2.2	4	4	430	1450
361.1	265	1900	1900	2590	2.2	4	4	645	1510
361.2	290	1900	1900	2590	3	4	4	680	1620
361.3	320	1900	1900	2890	3	4	4	720	1740
528.1	400	2400	2200	2650	3	2 x 3	6	895	2950
528.2	460	2400	2200	2650	4	2 x 3	6	950	3075
528.3	500	2400	2200	2950	5.5	2 x 3	6	1000	3270
748.2	570	3400	2200	3620	5.5	2 x 4	6	1300	4100
748.3	720	3400	2200	3920	7.5	2 x 4	6	1380	4490
967.2	815	4300	2200	3690	7.5	2 x 4	6	1450	5150
967.3	890	4300	2200	3690	11	2 x 4	6	1550	5550
1333.1	1150	4300	3100	4100	11	3 x 3	2 x 4	2230	8300
1333.2	1300	4300	3100	4100	11	3 x 3	2 x 4	2385	8500
1333.3	1430	4300	3100	4100	15	3 x 3	2 x 4	2510	8700
1849.1	1600	4300	4300	4000	15	3 x 4	2 x 6	3050	11050
1849.2	1770	4300	4300	4000	18.5	3 x 4	2 x 6	3240	11250
1849.3	1840	4300	4300	4000	22	3 x 4	2 x 6	3410	11850

FRP Closed Circuit Cooling Towers

Principals of operation

FRP Closed Circuit Cooling Towers act quite like open circuit cooling towers, the only deference is that in FRP Closed Circuit Cooling Towers the fluid to be cooled (usually water) flows through the tubes of the coil without coming into direct contact with external air, preventing dirt or pollution entering the primary water circuit.

The heat is transmitted from the fluid through the tube walls to the water, which is being continuously sprayed over the coil.

The fan situated at the top of the tower intakes air in counter flow to water, thereby evaporating a small part of the re-circulating water, drawing off the necessary heat for evaporation and releasing it into the atmosphere.

The rest of water is re-circulated with a spray water pump from the basin to the spray nozzles. (Secondary Circuit).

A small quantity of heat is transmitted by convention to the external air, just as for an air cooler.

In closed circuit cooling towers there are two separated circuits.

1. Initial circuit which process fluid is circulating
2. Secondary circuit which sprays the water on the coil.

Fan

The light weight fan has good corrosion-resistant quality is an axial flow, multi blade version with adjustable blade pitch. The fan is designed to deliver large volumes of air at low power consumption and low noise generation.

Driving system

Movement transfer from the electromotor to fan would be delivered through a series of belt, pulley and fly wheel. (Belt Drive)

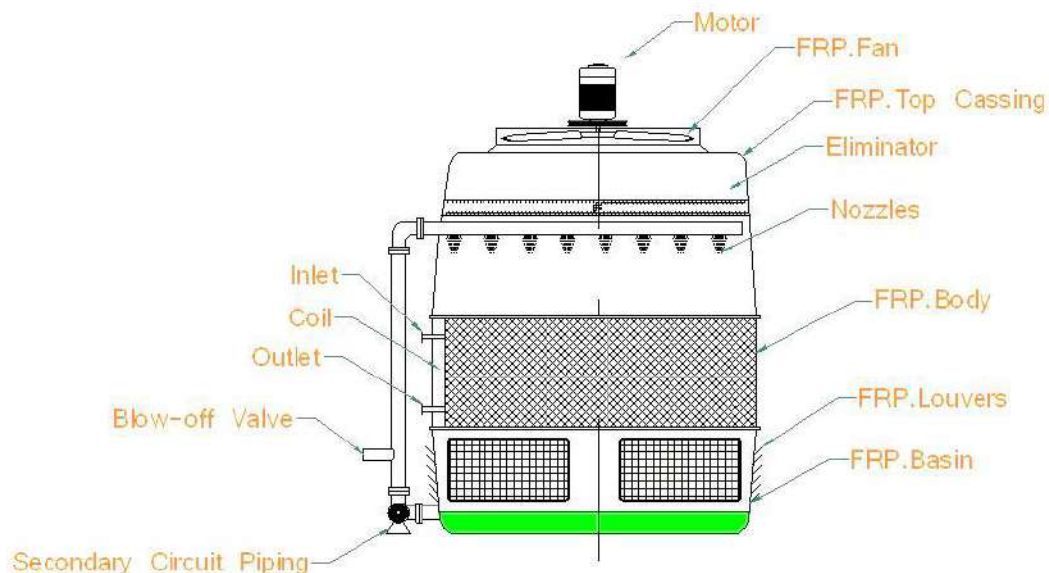

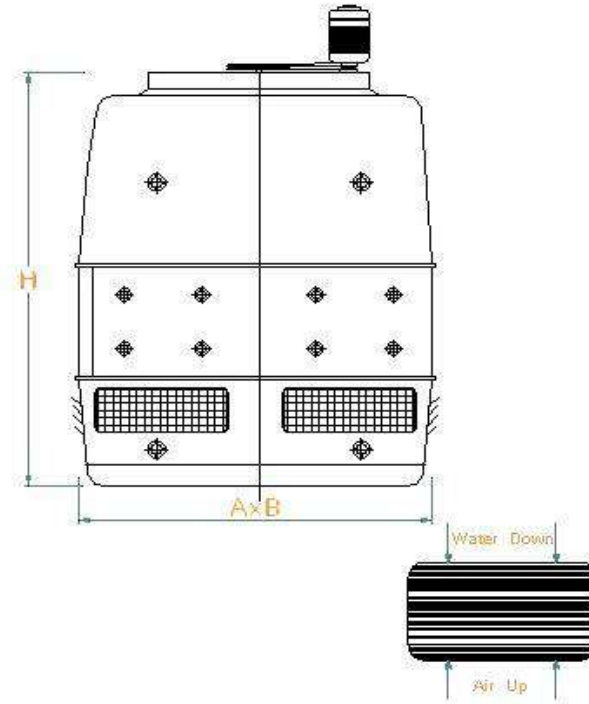

Table 7

Model	Dimensions (mm)			Motor power Kw	Motor power Kw	Inlet (inch)	Outlet (inch)	Weight Kg	
	Length	Width	Height					Dry	Full
169.2	1300	1300	2320	1.5	0.75	2 ½	2 ½	700	1300
169.3	1300	1300	2620	1.5	0.75	2 ½	2 ½	800	1400
169.4	1300	1300	2620	1.5	0.75	2 ½	2 ½	950	1550
272.3	1650	1650	2660	2.2	0.75	3	3	1250	2250
272.4	1650	1650	2660	2.2	0.75	3	3	1450	2400
272.5	1650	1650	2960	3	1.1	3	3	1700	2700
361.4	1900	1900	2890	3	1.1	2 x 2 ½	2 x 2 ½	1826	3300
361.5	1900	1900	3190	4	1.5	2 x 2 ½	2 x 2 ½	2190	3540
484.4	2200	2200	2950	4	1.5	2 x 3	2 x 3	2090	4250
484.5	2200	2200	3250	5.5	2.2	2 x 3	2 x 3	2440	4600
484.6	2200	2200	3550	7.5	2.2	2 x 3	2 x 3	2850	5010
575.5	2400	2400	3550	7.5	2.2	2 x 4	2 x 4	2960	5460
575.6	2400	2400	3850	7.5	2.2	2 x 4	2 x 4	3430	5930
967.5	4300	2250	3980	11	3	3 x 3	3 x 3	4858	10885
967.6	4300	2250	4280	11	3	3 x 3	3 x 3	5720	11950
1333.5	4300	3100	4360	15	2 x 2.2	4 x 3	4 x 3	7895	15000
1333.6	4300	3100	4660	15	2 x 3	4 x 3	4 x 3	9000	16900
1849.5	4300	4300	4300	22	2 x 3	6 x 3	6 x 3	9800	24000
1849.6	4300	4300	4600	22	2 x 3	6 x 3	6 x 3	11100	26000

Electromotor

Single speed electromotor, Standard TEFC with IP55, "F" class are used in "Tahviah Sarayel Nasim" cooling Towers.

Drift Eliminator

PVC drift eliminator with three changes in air path gives less than 0.002% drift loss.

Circulating water pump

Circulating water pump is a piece of closed circuit cooling tower which is designed to spray water on the Heat exchange coil and its electromotor would be cooled by fan (TEFC). Exit valve for Bleed off is Considered in pump circuit.

Industrial Cooling Towers

Principals of "Tahviah Sarayel Nasim" Industrial Cooling Towers is using finest raw materials and the highest Quality parts from well-known industries are used in "Tahviah Sarayel Nasim" cooling towers in order to Ensure the high quality of tower in worst working conditions.

All pieces can easily be carried, and makes fast installation at site results an integrated rigid cooling tower. "Tahviah Sarayel Nasim" Cooling Towers are designed such as to use the modern polymeric substances as Much as possible.

Fan deck, fan stack and casing are manufactured from fiberglass reinforced polymer, packing and drift Eliminators from PVC sheets or other polymer substances. The water distribution system would be through The PVC high pressure pipes and large orifice nozzles (non-clogging) made of polymers.

The main structure would be made of fabric steel profiles which after manufacturing processes hot dipped Galvanized and then covered by a fiberglass layer.

Fast and rigid Installation All the pieces would be easily installed by a couple of bolts and there is no need To any extra operation.

Rigid structure

The Structure of "Tahviah Sarayel Nasim" cooling towers are made of galvanized steel fabric profiles which has provided the resistant structure and long lasting towers at peak industrial conditions.

Fills

The fills section is designed to bring about intimate contact of water and air so as to facilitate heat and mass Transfer at the same time aiding in proper and even distribution of air and water over the cross section, while maintaining minimum pressure downfall. The fills are of honeycomb section and are vacuum formed

From anti- Bacterial Virgin PVC for excellent resistance to corrosion and give maximum area for Wattage.

Fans

Multi wings powerful axial Fan with high efficiency and low power consumption is one of the Best options for industrial cooling towers. FRP fan blades may also be provided on demand and these have In addition to excellent corrosion-resistance, good noise reduction properties.

Moving System

Movement transfer from The electromotor to fan would occurred by means of shaft (greaducer drive) or by pulley ,flywheel and a series of belts. (Belt drives)

Electromotor

Single speed electromotor, Standard TEFC with IP55, "F" class are used in "Tahviah Sarayel Nasim" cooling Towers.

Casing, Fan Stack, Fan Deck

"Tahviah Sarayel Nasim" Cooling Towers packing are enclosed by fiberglass casings. Fan Stack and Fan Deck Are also made of fiberglass and designed as if the air suction occurs based on air path model.

Water distribution system

The water distribution system is designed in such a way that provides the easy service and low pressure. Large orifice polymeric nozzles (Non-clogging) are one of the significant, benefits of industrial towers.

Drift Eliminator

"Tahviah Sarayel Nasim" Industrial cooling towers drift eliminators are made of PVC with three changes in air Path and high efficiency. The drift Loss would be less than 0.002% by using these drifts eliminators.

Louvers

FRP louvers are installed at the air inlet (space between the Tower casing and water Basin) to prevent water Splash and prevents leaves, bird etc., entering the Cooling Tower. They could be easily detached to Access the tower's basin.

Technical Specifications

"Tahviah Sarayel Nasim" Industrial Cooling Towers are made and designed based on assumptions of client's requirements (suitable to be installed on a concrete basin).

The concrete basin plan would be delivered to the client after the agreement, so that the civil contractor of client can construct the concrete basin as the "Tahviah Sarayel Nasim" is manufacturing the pieces of Tower.